

## EDGE Performance:

Compliant with Australian standards | Strength | Energy rated | Cost savings | Watershed drainage system  
 Use MAX and U-MAX™ systems on different facades to meet energy requirements  
 High performance co-extruded anti drop out gaskets  
 Local technical support | Project based design assistance | Australian produced, with reliable supply chain

## EDGE Principles:

Legacy-free, greenfield design | Full metric footprint | Australian designed for Australian conditions  
 Design freedom | MAX non-broken systems & U-MAX™ thermally broken systems  
 EDGE systems are visually identical | Mix & match to easily combine systems into one façade | No visible drain slots in transoms  
 Concealed drainage system | Captivated beads cannot fall out  
 Captivated pocket design for ease of glazing | Internal or external glazed

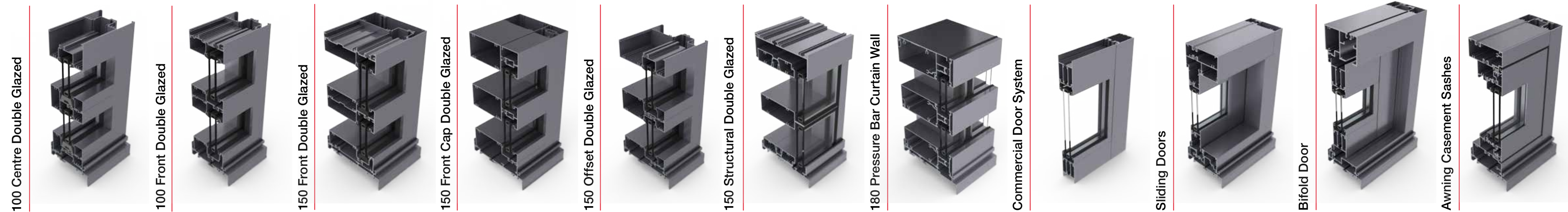

Your project, your choice: These systems are available in thermally broken U-MAX™, and non thermally broken MAX. Use together for a seamless transition around a building that meets your thermal requirements. Visit [www.edgearchitectural.com.au](http://www.edgearchitectural.com.au) to learn more, access our technical manuals and register to receive more information.



## Discovery

Led by our principles and a quest to find a better way, the EDGE Research & Development team set out to change Australia's commercial architectural frame industry. Our journey took us around the world to assess best practices in other countries and around Australia to consult with our clients.

After much toil, testing and trial, U-MAX™ and MAX emerged. Together they form a complete and interchangeable range of double glazed aluminium architectural frames that meet all of the Australian standards.

Creating something new only works if that something new delivers benefits. EDGE Architectural offers benefits in spades.

- Your projects can enjoy
- visual unity
  - strength
  - design flexibility
  - performance
  - quality control
  - local service & support
  - warranties

## Revolution

U-MAX™, EDGE Architectural's thermally broken double glazed suite, represents a revolution in Australian architectural glazing systems.

With versatility and consistency driving its design, U-MAX™ offers a complete, energy efficient range of products. We took a holistic approach towards development. It's not a frame or even a window; it's a system with unique DNA and an ecosystem supporting it. We subjected every feature to brutal scrutiny to ensure each part contributed to the whole.

As a result, U-MAX™ delivers strength and conservation, flexibility and design freedom, innovation and performance.

Our philosophy is to offer creative, streamlined and efficient solutions, without compromise. Join the U-MAX™ revolution.

## Harmony

Life is not one size fits all. And neither are your designs. Enter MAX.

MAX, EDGE Architectural's double glazed window frames suite, adopts all the products from the U-MAX™ range in non-broken form, complemented by additional frame selections. Like U-MAX™, MAX offers an array of interchangeable systems and door and sash elements to provide a comprehensive efficient range of products that meet all the Australian standards.

Use MAX and U-MAX™ together on a project for a seamless transition across façades, selecting the correct product for the required energy rating and the desired visual impact. The result is cost control in harmony with stunning aesthetics throughout the project.

Your designs are personal. Choose MAX and U-MAX™ to infuse them with your personality.

## view from the EDGE

### Who is EDGE Architectural?

We are  
Problem solvers.  
Systems designers.  
Status quo questioners.  
Customer service fanatics.  
Project partners.  
Fresh thinkers.  
Builders for life.

EDGE Architectural Systems maintains one of Australia's most comprehensive range of shopfront and façade framing systems. Our stunning range of double glazed systems, featuring thermal break, give our clients the design freedom they seek for innovative projects.

As a division of Aluminium Industries of Australia, our team of professionals all share a passion for what we do and a clear understanding that our success comes from helping our clients succeed.

We are proudly Australian yet operate with a global perspective.

**EDGE**  
Architectural Glazing Systems

A division of Aluminium Industries  
Corporate Office  
160 Ordish Road, Dandenong South, Victoria 3175  
Phone: (+61) 3 9798 4133 | Fax: (+61) 3 9798 4499  
[www.edgearchitectural.com.au](http://www.edgearchitectural.com.au)

ai Division of Aluminium Industries of Australia Pty Ltd. [www.aluminium.com.au](http://www.aluminium.com.au)

the future of  
architectural  
framing  
systems

**EDGE**  
Architectural Glazing Systems

## Performance by Principle

EDGE Architectural breathes elegance, flexibility and imagination into Australia's commercial aluminium window and door systems.

The design principles behind the EDGE ranges allow for a seamless transition between thermal and non thermal façade appearance. Similarly, front, centre and offset glazed systems can be reversed and combined to change the glass plane. Adaptability is the key.

EDGE Architectural delivers design freedom within energy efficient window and door framing systems. Your projects can have it all. We can show you how.

## Your legacy, our innovation

Your personality, your philosophy, your vision. With every project, you build your legacy and cement your reputation. It's your signature on the future. Sign it on the EDGE and build for life.

With little significant innovation of Australia's commercial window systems since the 60s, we dared to be different and developed a completely new product range with fresh feature sets across it. We adopted international best practices for energy conservation and adapted them for Australian conditions to meet Australian standards.

The U-MAX™ and MAX double glazed suites were designed and tested for reliability, longevity and energy efficiency, but also for beauty and interchangeability. You choose the right system, with the right features and performance to achieve your vision for your project.

EDGE Architectural Glazing Systems gives you options, including:

- Seamless integration between suites
- Unbroken and thermally broken suites
- Front, centre and offset glazing
- No visible drain slots
- Our Watershed drainage system that redirects water safely through the façade

Sensory experiences comprise a person's impression of a structure. The light, the air, looking through a window, opening a door; people judge a building by how it makes them feel. Ensure people experience your projects as you intend. The MAX and U-MAX™ double glazed suites complement one another, allowing you to achieve the form and function you want for today and the future.

Free your design and the rest will follow.

**EDGE**  
Architectural Glazing Systems  
building for life  
[www.edgearchitectural.com.au](http://www.edgearchitectural.com.au)